

TSX - TLX

Technical Data



TSX - TLX Technical Data

VDI 2198

Specification	1.1	Manufacturer		OM	OM		
	1.2	Model designation		TSX 20	TSX 30	TLX 20	
	1.3	Power: (electric,diesel,petrol)		Electric	Electric	Electric	
	1.4	Operator type: hand, pedestrian, standing, seated, order-picker.		Pedestrian / Stand on platform		Pedestrian / Stand on platform	
	1.5	Load capacity	Q (t)	2	3	2	
	1.6	Load centre distance	c (mm)	600 ⁽¹⁾	600 ⁽¹⁾	600 ⁽¹⁾	
	1.8	Load distance	x (mm)	872	872	872	
	1.9	Wheelbase	y (mm)	1376 ⁽³⁾ - (1304) ⁽²⁾	1376 ⁽³⁾ - (1304) ⁽²⁾	1304	
Weights	2.1	Truck Weight (without battery)	kg	478 ⁽¹⁾ - (503) ⁽¹⁾	478 ⁽¹⁾ - (503) ⁽¹⁾	352 ⁽¹⁾	
	2.2	Axle loading with load	load side / driver side	kg	1783/983 - (1787/996) ⁽³⁾ 1748/967 - (1750/974) ⁽²⁾	2590 / 1194 -	1722/844 - (1676/978) -
	2.3	Axle loading without load	load side / driver side	kg	178/588 - (182/601) ⁽³⁾ 165/550 - (167/556) ⁽²⁾	182 / 601 -	115/449 - (79/575) -
Wheels and Tyres	3.1	Tyres: solid rubber, Polyurethane.		Polyurethane	Polyurethane	Polyurethane	
	3.2	Tyre size load side	mm	85 X 70	85 X 70	85 x 90	
	3.3	Tyre size driver side	Drive wheel / Swivel castor wheel	mm	250 / 95	250 / 95	230 / 100
	3.5	Wheels number load side / driver side (x=drive wheel)		4 / 1x-2	4 / 1x-2	2 / 1x-2	
	3.6	Tread load side	b ₁₀ (mm)	398 - [(358) ⁽⁸⁾ - (488) ⁽⁹⁾	398 - [(358) ⁽⁸⁾ - (488) ⁽⁹⁾	398 - [(358) ⁽⁸⁾ - (488) ⁽⁹⁾	
	3.7	Tread drive side	b ₁₁ (mm)	/	/	/	
Dimensions and Overall Sizes	4.4	Lift height	h ₃ (mm)	135	135	135	
	4.9	Height of tiller arm in working position (min / max)	h ₁₄ (mm)	1145 / 1342	1145 / 1342	1145 / 1342	
	4.15	Lowered height	h ₁₃ (mm)	85	85	85	
	4.19	Overall length (Platform closed / open)	l ₁ (mm)	1926 / 2253 - [1854 / 2180] ⁽²⁾	1926 / 2253	1854 / 2180 ⁽¹⁾	
	4.20	Length to front face of forks (Platform closed / open)	l ₂ (mm)	776 / 1102 - [704 / 1030] ⁽²⁾	776 / 1102	704 / 1030	
	4.21	Overall width	b ₁ (mm)	710	710	710	
	4.22	Fork dimensions	s/e/l (mm)	50 / 162 / 1150 ⁽⁴⁾	50 / 162 / 1150 ⁽⁴⁾	50 / 162 / 1150 ⁽⁴⁾	
	4.25	Outside fork width dimension	b ₅ (mm)	560 [520 - 650]	560 [520 - 650]	560 [520 - 650]	
	4.32	Ground clearance centre of wheelbase	m ₂ (mm)	168	168	168	
	4.33	Aisle width pallets 1000 x 1200 crossways (Platform closed / open)	A _{st3} (mm)	1997 ^{(5) (6)} - 2676 ^{(5) (7)} 1925 ^{(5) (6)} / 2604 ^{(5) (7)}	(1827 / 2134) ^{(5) (6)} (2313 / 2620) ^{(5) (7)}	1925 ^{(5) (6)} / 2604 ⁽⁷⁾ -	
4.34	Aisle width pallets 800 x 1200 lengthwise (Platform closed / open)	A _{st3} (mm)	2197 ⁽⁶⁾ / 2694 ⁽⁷⁾ 2125 ⁽⁶⁾ / 2622 ⁽⁷⁾	(2197 / 2504) ⁽⁶⁾ (2387 / 2694) ⁽⁷⁾	2125 ⁽⁶⁾ / 2622 ⁽⁷⁾ -		
4.35	Turning radius (Platform closed / open)	W _a (mm)	1669 / 1976 - [1597 / 1904] ⁽²⁾	1669 / 1976	1597 / 1904		
Performance	5.1	Travel speed (with load / without load)	km/h	8,5 / 10,5	7,5 / 10,5	6/6 (7,5 ⁽¹¹⁾)	
	5.2	Lift speed (with load / without load)	m/s	0,032 / 0,041	0,030 / 0,045	0,034 / 0,045	
	5.3	Lowering speed (with load / without load)	m/s	0,05 / 0,037	0,045	0,045 / 0,045	
	5.7	Gradeability (with load / without load) ⁽¹⁾	%	*,* / *,*	*,* / *,*	0,7 ^{(1) (2) (10)} / 10,2 ^{(1) (2) (10)}	
	5.8	Max. Gradeability (with load / without load) ⁽¹⁾	%	-	10 / 18	4,7 ^{(1) (2) (10)} / 21,3 ^{(1) (2) (10)}	
Engine	5.10	Service brake		Electric	Electric	Electric	
	6.1	Drive motor, S2 60 minute rating	kW	2,5	2,5	1,2	
	6.2	Lifting motor, S3 10% rating	kW	1,2	2,2	1,2	
	6.3	Battery DIN 43531/35/36; A, B, C, no		DIN 43535 B	DIN 43535 B	DIN 43535 B	
	6.4	Battery voltage / capacity at 5 hour rate	V / Ah	24/330 (375) -24/220 (250)	24 / (330 - 375) ⁽³⁾	24/220 (250)	
	6.5	Battery weight(± 5%)	kg	288 (305) - 212 (220)	305	212 (220)	
Others	8.1	Drive control		Electronic	Electronic	Electronic	
	8.4	Sound level at the driver's ear according to DIN 12053	dB (A)	< 70	< 70	< 70	

The values presented are to be taken as indicative and not binding; they refer to the standard equipment

(1) Value referred to fork dimension l = 1150 x 560 mm
 (2) With battery compartment for DIN 24 V / 210 - 250 Ah
 (3) With battery compartment for DIN 24 V / 330 - 375 Ah
 (4) For different fork length available as option see chart page 1
 (5) with forks dimensions l = 980 mm
 (6) Value according to the normative for pedestrian pallet truck

(7) Value according to the normative for rider truck or high lift pallet truck
 (8) With outside forks dimension b5 = 520mm
 (9) With outside forks dimension b5 = 650mm
 (10) With opened platform
 (11) With Operator side gates

1 = Travel
2 = Braking

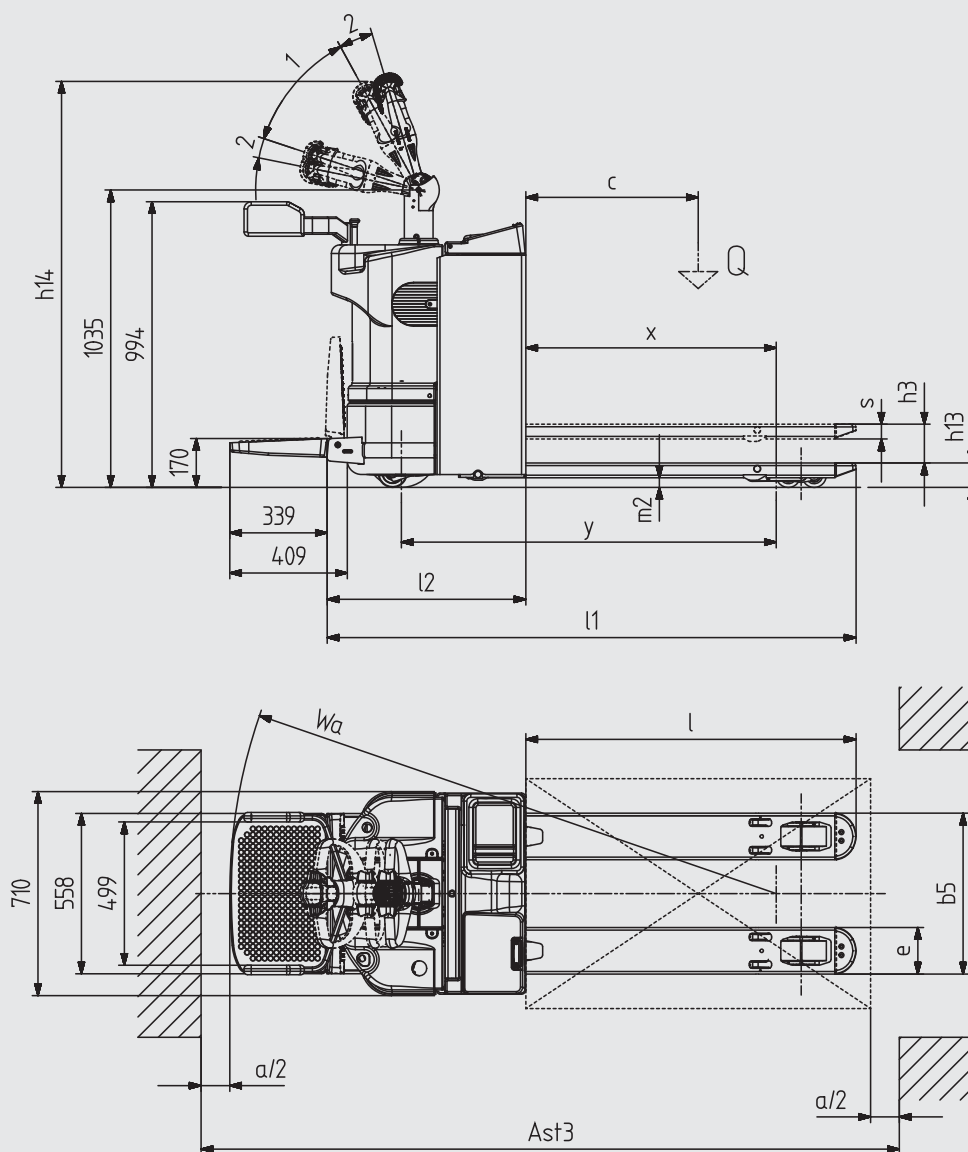

CHARACTERISTICS OF ALTERNATIVE LIFTS

			TSX 20-30								TLX 20							
			Standard wheelbase								Short wheelbase							
Fork dimensions		l mm	800	980	1150	1450	1600	1980	2160	2400	1980 pc	2160 pc	2400 pc	800	980	1150	1450	1600
		c mm	400	500	600	715	800	1000	1072,5	1200	1000	1072,5	1200	400	500	600	715	800
		x mm	522	702	872	1172	1322	1702	1882	2122	1354	1534	1774	522	702	872	1172	1322
Battery compartment DIN 24V 210 - 250 Ah		y mm	954	1134	1304	1604	1754	2134	2314	2554	1790	1970	2210	954	1134	1304	1604	1754
	Open platform	l_1 mm	1504	1684	1854	2154	2304	2684	2864	3104	2684	2864	3104	1504	1684	1854	2154	2304
	Open platform	W_a^* mm	1247	1427	1597	1897	2047	2427	2607	2847	2083	2263	2503	1247	1427	1597	1897	2047
	Closed platform	l_1 mm	1830	2010	2180	2480	2630	3010	3190	3430	3010	3190	3430	1830	2010	2180	2480	2630
Battery compartment DIN 24V 315 - 375 Ah	Closed platform	W_a^* mm	1554	1734	1904	2204	2354	2734	2914	3154	2390	2570	2810	1554	1734	1904	2204	2354
		y mm	1026	1206	1376	1676	1826	2206	2386	2626	1862	2042	2282					
	Open platform	l_1 mm	1576	1756	1926	2226	2376	2756	2936	3176	2756	2936	3176					
	Open platform	W_a^* mm	1319	1499	1669	1969	2119	2499	2679	2919	2155	2335	2575					
Closed platform	l_1 mm	1903	2083	2253	2553	2703	3083	3263	3503	3083	3263	3503						
	W_a^* mm	1626	1806	1976	2276	2426	2806	2986	3226	2462	2642	2882						

* Value referred with lifted forks

TSX - TLX

Pedestrian pallet truck with platform

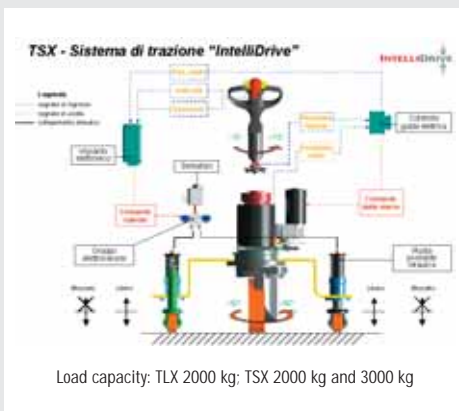

Chassi: The highest spec model in the TSX series has the 3-point support layout as the basic TLX model but includes **INTELLIDRIVE®**, a patented electro-hydraulic system that enhances the tractive features of the truck. The system adjusts the rear castor wheels (by means of two electronically driven hydraulic cylinders) to optimize the stability of the truck in any situation. Load capacity: TLX 2000 kg; TSX 2000 kg and 3000 kg. The motor compartment cover is made of polyethylene (PET), a flexible but strong material. The battery cover is also made of the same material and has ample storage space for objects and documents on top. The standard TLX model has a compact battery compartment (up to 250 Ah), but can be ordered with a large battery compartment (up to 375 Ah) upon request. All the batteries comply with DIN 43535 B standards.

Driver's platform: The platform has a soft rubber mat and a non slip surface that provides maximum operator comfort and safety. The platform is only 170 mm from the ground and when the driver is on board, lowers even further to facilitate easy demounting of the machine. The side guards (optional on the TLX) are padded with polyurethane foam and are at an ideal height for the safe and effective protection of the operator on the platform. The special design of these guards and their simple but secure opening/closing system allow the truck to be easily reconfigured. The one piece tiller is manufactured from very light but sturdy plastic; the ergonomic handle and optimized layout of the controls create optimal driving conditions. The light finger tip pushbuttons can be operated easily. The tiller provides electric power-assisted steering to reduce operator fatigue and offers maximum comfort stationary and at top speed.

Traction unit: The separately excited traction motors have a rated power of 1.2 kW (TLX) and 2.5 kW (TSX). This feature with the dedicated software offer the benefits of both separate excitation and series excitation: Speed control when laden, unladen, and on gradients. ■ Energy recovery system with reduced energy consumption.

Braking: The truck has two separate braking systems: ■ Service brake ➔ Inversion braking on the traction motor (regenerative braking) performed by the electronic control when the butterfly direction control is released ■ Handbrake ➔ Electromagnetic brake.

Electronic system: The electronic system with MOSFET technology controls both traction and lift motors. The CANBUS serial transmission of electronic signals, reduces the wiring, and the use of automotive connectors all contribute to an excellent record of reliability. The Temperature Control System in the TLX model controls the temperature of the traction electronics by means of a forced air ventilation system, while the tiller electronic card made with multilayer technology is equipped with a system that maintains the temperature of the logic unit within a predetermined range. This feature has two very important benefits in that it: ■ Reduces condensation on the tiller logic unit. ■ Increases the average life of the electronic components.

By using proximity sensors instead of mechanical microswitches and reducing the number of remote control switches, the truck has a technical configuration that greatly reduces maintenance costs. The steering motor is controlled by a dedicated MOSFET electronic card.

Technical data are given as an indication.
OM Carrelli Elevatori reserves the right to modify them without notice.

OM Carrelli Elevatori S.p.A.
Viale A. De Gasperi, 7
I-20020 Lainate (MI)
Tel.: +39(02)937 65-1
Fax: +39(02)937 65-450
www.om-mh.com