

CTX - CTXi Technical Data



CTX - CTXi Technical Data

VDI 2198

Specification	1.1	Manufacturer		OM	OM	OM	OM
	1.2	Manufacturer type designation		CTX 14	CTX 20	CTXi 14	CTXi 20
	1.3	Drive unit: electric (battery or mains), diesel, petrol, fuel gas		Electric	Electric	Electric	Electric
	1.4	Operator type: hand, pedestrian, standing, seated, order-picker		Pedestrian	Pedestrian	Pedestrian	Pedestrian
	1.5	Load capacity	Q (t)	1,4	2	1,4 (2 ⁽¹⁾)	2 (2 ⁽¹⁾)
	1.6	Load center	c (mm)	600	600	600	600
	1.8	Load distance, centre of drive axle to fork face	x (mm)	711 (2)	706 (2)	645 (2) (12)	640 (2) (12)
	1.9	Wheelbase	y (mm)	1323	1323	1359 (12)	1359 (12)
Weights	2.1	Truck weight (without battery)	kg	971 (3)	1013 (3)	1062 (3)	1105 (3)
	2.2	Axle loading, loaded (front/ rear)	kg	1620 / 1011 (3)	2208 / 1101 (3)	1619 / 1222 (3) (11)	2194 / 1289 (3) (11)
	2.3	Axle loading, unloaded (front/ rear)	kg	338 / 893 (3)	368 / 940 (3)	358 / 1083 (3) (11)	382 / 1101 (3) (11)
Wheels and Tyres	3.1	Tyres: solid rubber, superelastic, pneumatic, polyurethane		Polyurethane	Polyurethane	Polyurethane	Polyurethane
	3.2	Tyre size (front)	mm	230 / 140	230 / 140	230 / 140	230 / 140
	3.3	Tyre size (rear)	mm	85 x 90	85 x 70	85 x 70	85 x 70
	3.5	Wheels number, front / rear (x= driven wheels)		2 / 1x-1	4 / 1x-1	4 / 1x-1	4 / 1x-1
	3.6	Tread, front	b10 (mm)	380	380	380	380
	3.7	Tread, rear	b11 (mm)	578	578	578	578
Dimensions and Overall Sizes	4.2	Height, mast lowered	h1 (mm)	2327	2327	2332	2332
	4.3	Free lift	h2 (mm)	140	90	140	90
	4.4	Lift height	h3 (mm)	3580	3580	3580	3580
	4.5	Height, mast extended	h4 (mm)	4066 (4)	4088 (4)	4070 (4)	4092 (4)
	4.6	Initial lift	h5 (mm)	/	/	135	135
	4.9	Height of tiller in drive position (min / max)	h14 (mm)	1145 / 1342	1145 / 1342	1145 / 1342	1145 / 1342
	4.15	Forks height, lowered	h13 (mm)	86	86	91	91
	4.19	Overall length (open/closed platform)	l1 (mm)	2049 / 2376	2064 / 2381	2161 / 2485	2168 / 2492
	4.20	Length to face of forks (open/closed platform)	l2 (mm)	899 / 1226	914 / 1231	1007 / 1330	1012 / 1335
	4.21	Overall width	b1 (mm)	860	860	860	860
	4.22	Fork dimensions	s/e/l (mm)	66 / 190 / 1150	61 / 200 / 1150	66 / 190 / 1150	61 / 200 / 1150
	4.24	Fork carriage width	b3 (mm)	680	680	680	680
	4.25	Maximum forks width	b5 (mm)	570	570	570	570
	4.31	Ground clearance, laden, below mast	m1 (mm)	/	/	/	/
	4.32	Ground clearance, centre of wheelbase	m2 (mm)	30	30	25 / 160 (12)	25 / 160 (12)
	4.33	Aisle width pallets 1000x1200 (1200 forking side) open/closed	Ast3 (mm)	2499 / 2801	2555 / 2857	2572 / 2870 (12)	2575 / 2873 (12)
	4.34	Aisle width pallets 800x1200 (800 forking side) open/closed	Ast3 (mm)	2465 / 2769	2554 / 2856	2559 / 2857 (12)	2563 / 2861 (12)
	4.35	Turning radius	Wa (mm)	1633 / 1937	1633 / 1937	1675 / 1973 (12)	1675 / 1973 (12)
Performance	5.1	Travel speed: Loaded / unloaded	km/h	6,5 / 8	5 / 8	6,5 / 8	5 / 8
	5.2	Lift speed: Loaded / unloaded	m/s	0,16 / 0,26 (6)	0,10 / 0,17	0,16 / 0,26	0,10 / 0,17
	5.3	Lowering speed: Loaded / unloaded	m/s	0,40 / 0,36	0,30 / 0,23	0,40 / 0,36	0,30 / 0,23
	5.7	Gradeability KB 15': Loaded / unloaded	%	1,3 / 4,8 (3)	0,4 / 4,1 (3)	1,2 / 4,1 (3) (9)	0,4 / 4 (3) (9)
	5.8	Max gradeability KB 5': Loaded / unloaded	%	3,9 / 9,1 (3) (10)	2,8 / 9,1 (3) (10)	3,6 / 8 (3) (9)	2,7 / 8 (3) (9)
	5.10	Service brake		Electric	Electric	Electric	Electric
Engine	6.1	Drive motor rating S2 60min	kW	1,2	1,2	1,2	1,2
	6.2	Lift motor rating at S3 15%	kW	2,2 (5) / 3	3	3	3
	6.3	Battery according to British Standard / DIN 43531/35/36 A, B, C		DIN	DIN	DIN 43535 B	DIN 43535 B
	6.4	Battery voltage / nominal capacity k5	V / Ah	24 / 240 (315 - 375)	24 / 315 (375)	24 / 330 (375)	24 / 330 (375)
	6.5	Battery weight (± 5%)	kg	260 (295 - 304)	295 (304)	288 (305)	288 (305)
Others	8.1	Control unit type		Electronic	Electronic	Electronic	Electronic
	8.4	Sound level at the driver's ear according to DIN 12 053	dB (A)	< 70	<70	<70	<70

The values presented are to be taken as indicative and not binding: they refer to the standard equipment

- (1) Used like transpallet
- (2) -20 mm with TPX mast
- (3) With SX mast h3= 3580 & Min. nominal battery capacity (see weight, line 6.5)
- (4) h4 = 490 mm with load back rest
- (5) Value for masts with height till h3= 3580mm included
- (6) Mast not available for model CTXi

- (7) + 5 mm for model CTXi
- (8) Performance obtained with lift motor 3 Kw
- (9) Max gradeability due to overall dimension 18.3%
- (10) Max gradeability due to overall dimension 9.1%
- (11) Value referred in condition with legs lowered (h5=0 mm)
- (12) Value referred in condition with legs extended (h5=135 mm)

1= Travel
2= Bracking

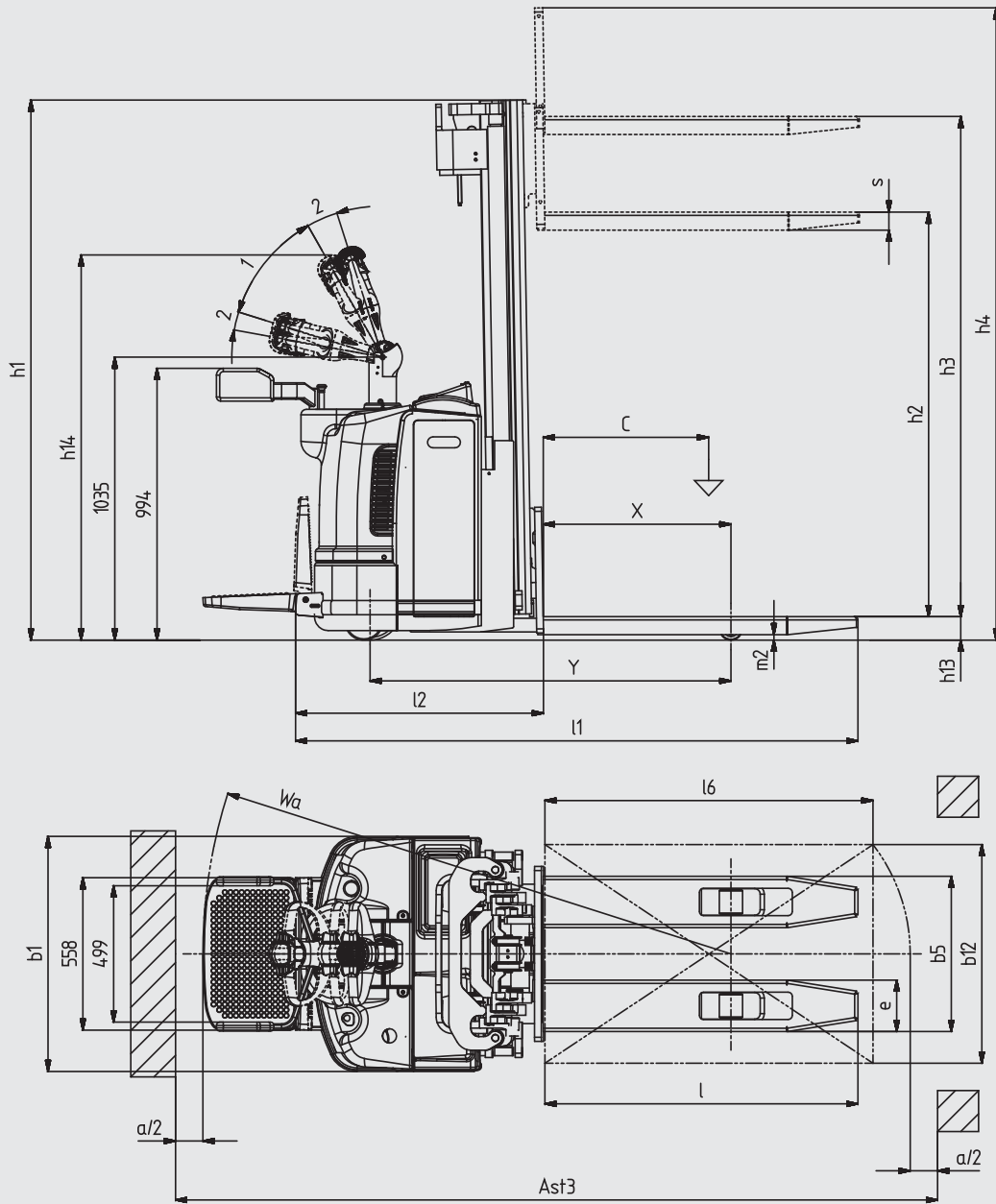

CHARACTERISTICS OF ALTERNATIVE LIFTS

		Mono ⁽⁶⁾ Simplex				Duplex				Triplex				
1.4 t MAST TYPE	Lift height	h_3	mm	1510 ⁽⁶⁾	2900	3580	3980	4480	2990	3600	4170	4470	4940	5390
	Height, mast lowered ⁽⁷⁾	h_1	mm	1977	1977	2327	2527	2777	1977	2327	1877	1977	2177	2327
	Free lift	h_2	mm	1491	140	140	140	140	1491	1810	1391	1491	1660	1810
	Height, mast extended ⁽⁷⁾	h_4	mm	1996	3386	4066	4466	4966	3476	4086	4656	4956	5426	5876
2.0 t MAST TYPE	Lift height	h_3	mm	-	2900	3580	-	-	-	-	4380	-	-	-
	Height, mast lowered ⁽¹¹⁾	h_1	mm	-	1977	2327	-	-	-	-	1977	-	-	-
	Free lift	h_2	mm	-	90	90	-	-	-	-	1469	-	-	-
	Height, mast extended ⁽¹¹⁾	h_4	mm	-	3408	4088	-	-	-	-	4888	-	-	-

CTX - CTXi Pedestrian stacker with mast and Flip Down platform

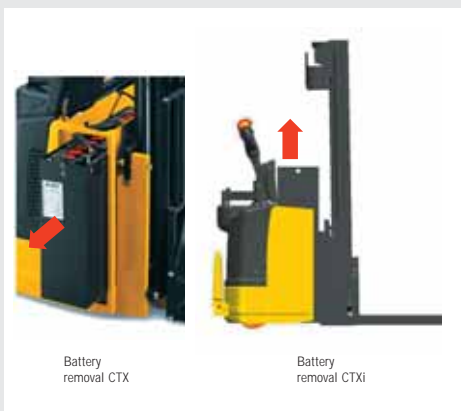

This OM Pedestrian Stacker with mast and flip down platform is designed to provide maximum safety and ergonomic operating conditions. The most dependable and tested technologies guarantee the high degree of reliability and productivity of these trucks even in the most difficult operating conditions. The CTXi version is equipped with the initial lift function. Standard power-assisted tiller steering on both the CTX and CTXi.

Frame: Four-point support configuration with fixed side traction unit and one anti-roll wheel. This configuration provides stability and a high level of residual capacity, essential elements for a forklift truck with mast. The motor compartment cover is made of polyethylene (PET), which is a flexible but strong material. The battery cover is also made of the same material with ample storage space for objects and documents on top.

The CTX and CTXi models can be configured with different chassis and two types of mast with a rated load capacity of 1400 kg and 2000 kg.

A wide range of lift masts is available: Simplex, Duplex and Triplex providing ample visibility forward. The forks are lifted and lowered by operating a butterfly on the tiller, which operates a proportional valve.



Driver's platform: The platform has a soft rubber mat and a non slip surface that provides maximum operator comfort and safety. The platform is only 170 mm from the ground and when the driver is on board, lowers even further to facilitate easy demounting of the machine. The side guards are padded with polyurethane foam and are at an ideal height for the safe and effective protection of the operator on the platform. The special design of these guards and their simple but secure opening/closing system allow the truck to be easily reconfigured.

The one piece tiller is manufactured from very light but sturdy plastic; the ergonomic handle and optimized layout of the controls create optimal driving conditions. The light finger tip pushbuttons can be operated easily. The tiller provides electric power-assisted steering to reduce operator fatigue and offers maximum comfort stationary and at top speed.

Traction unit: The separately excited traction motors have a rated power of 1.2 kW. This feature with the dedicated software offer the benefits of both separate excitation and series excitation: Speed control when laden, unladen, and on gradients. ■ Energy recovery system with reduced energy consumption.

Braking: The truck has two separate braking systems:

- Service brake ⇒ Inversion braking on the traction motor (regenerative braking) performed by the electronic control when the butterfly direction control is released.
- Handbrake ⇒ Electromagnetic brake.

Technical data are given as an indication.

OM Carrelli Elevatori reserves the right to modify them without notice.



OM Carrelli Elevatori S.p.A.
Viale A. De Gasperi, 7
I-20020 Lainate (MI)
Tel.: +39(02)937 65-1
Fax: +39(02)937 65-450
www.om-mh.com