

TL Technical Data



TL Technical Data

VDI 2198

Specification	1.1	Manufacturer	OM	OM	OM	OM	OM	1.1		
	1.2	Model designation	TL 14	TL 16	TL 18	TL 20	TL 20	1.2		
	1.3	Power: battery, diesel, LPG, electric mains	Electric	Electric	Electric	Electric	Electric	1.3		
	1.4	Operation: manual, pedestrian, stand.on, seated, orderpicker	Pedestrian	Pedestrian	Pedestrian	Pedestrian	Pedestrian	1.4		
	1.5	Load capacity	Q (t)	1,4	1,6	1,6	1,8	1,8	2,0	1.5
	1.6	Load centre	c (mm)	600	600	600	600	600	600	1.6
	1.8	Load distance	x (mm)	914	914	914	914	914	914	1.8
	1.9	Wheelbase	y (mm)	1275	1275	1342	1275	1342	1342	1.9
Weights	2.1	Unladen weight	kg	325	432	512	432	512	512	2.1
	2.2	Axle loading with load (front/rear)	kg	591 / 1134	723 / 1309 ⁽²⁾	762 / 1350 ⁽³⁾	772 / 1460 ⁽²⁾	808 / 1503 ⁽³⁾	855 / 1657 ⁽³⁾	2.2
	2.3	Axle loading without load (front/rear)	kg	251 / 74	336 / 96 ⁽²⁾	395 / 117 ⁽³⁾	336 / 96 ⁽²⁾	395 / 117 ⁽³⁾	395 / 117 ⁽³⁾	2.3
Wheels and Tyres	3.1	Tyres Rubber, Pneumatic shaped solid, Pneumatic, Polyurethane		Rubber	Rubber	Rubber	Polyurethane	Polyurethane	Polyurethane	3.1
	3.2	Tyre size, front	mm	230x75 / 100x40	230x75 / 100x40	230x75 / 100x40	230x75 / 100x40	230x75 / 100x40	230x75 / 100x40	3.2
	3.3	Tyre size, rear	mm	85X100	85X100	85X100	85X100	85X100	85X100	3.3
	3.5	Wheels, number front/rear (x = driven)		1x - 2 / 2	1x - 2 / 2	1x - 2 / 2	1x - 2 / 2	1x - 2 / 2	1x - 2 / 2	3.5
	3.6	Front axle width	b ₁₀ (mm)	458	458	458	458	458	458	3.6
	3.7	Track width, rear	b ₁₁ (mm)	350 / 390 / 510	350 / 390 / 510	350 / 390 / 510	350 / 390 / 510	350 / 390 / 510	350 / 390 / 510	3.7
Dimensions and Overall Sizes	4.4	Lift height	h ₃ (mm)	123	123	123	123	123	123	4.4
	4.9	Height of tiller arm in working position min./max.	h ₁₄ (mm)	870 / 1327	870 / 1327	870 / 1327	870 / 1327	870 / 1327	870 / 1327	4.9
	4.15	Lowered height	h ₁₃ (mm)	85	85	85	85	85	85	4.15
	4.19	Overall length	l ₁ (mm)	1660	1660	1727	1660	1727	1727	4.19
	4.20	Length to face of forks	l ₂ (mm)	510	510	577	510	577	577	4.20
	4.21	Overall width	b ₁ (mm)	720	720	720	720	720	720	4.21
	4.22	Fork dimensions	s/e/l (mm)	52 / 170 / 1150 ⁽⁴⁾	52 / 170 / 1150 ⁽⁴⁾	52 / 170 / 1150 ⁽⁴⁾	52 / 170 / 1150 ⁽⁴⁾	52 / 170 / 1150 ⁽⁴⁾	52 / 170 / 1150 ⁽⁴⁾	4.22
	4.25	Outside fork width	b ₅ (mm)	520 / 560 / 680	520 / 560 / 680	520 / 560 / 680	520 / 560 / 680	520 / 560 / 680	520 / 560 / 680	4.25
	4.32	Ground clearance centre of wheelbase	m ₂ (mm)	36	36	36	36	36	36	4.32
	4.33	Aisle width with pallets 1000 x 1200 crossways	Ast ₃ (mm)	1897	1897	1964	1897	1964	1964	4.33
	4.34	Aisle width with pallets 800 x 1200 lengthwise	Ast ₃ (mm)	2097	2097	2164	2097	2164	2164	4.34
	4.35	Turning radius	W _a (mm)	1611	1611	1678	1611	1678	1678	4.35
Performance	5.1	Travel speed (with/without load)	km/h	5 / 5	6 / 6	6 / 6	6 / 6	6 / 6	6 / 6	5.1
	5.2	Lift speed (with/without load)	m/s	0,039 / 0,047	0,039 / 0,047	0,039 / 0,047	0,039 / 0,047	0,039 / 0,047	0,039 / 0,047	5.2
	5.3	Lowering speed (with/without load)	m/s	0,072 / 0,028	0,087 / 0,037	0,087 / 0,037	0,044 / 0,044	0,044 / 0,044	0,044 / 0,044	5.3
	5.8	Max. gradeability KB 5° (with/without load)	%	10 ⁽⁴⁾ / 20 ^{(5) (6)}	10 ⁽⁴⁾ / 20 ^{(5) (6)}	10 ⁽⁴⁾ / 20 ^{(5) (6)}	9 ⁽⁴⁾ / 20 ^{(5) (6)}	9 ⁽⁴⁾ / 20 ^{(5) (6)}	8 ⁽⁴⁾ / 20 ^{(5) (6)}	5.8
	5.10	Service brake		Electric	Electric	Electric	Electric	Electric	Electric	5.10
Engine	6.1	Drive motor, S2 60 minute rating	kW	1	1	1	1	1	1	6.1
	6.2	Lifting motor, S3 15% rating	kW	1	1	1	1	1	1	6.2
	6.3	Battery DIN 43531/35/36 A, B, C, no		/	British Standard	DIN 43535 B	British Standard	DIN 43535 B	DIN 43535 B	6.3
	6.4	Battery voltage/capacity at 5 hour rate	V/Ah	2x12 / 44	24 / 110 (150)	24 / 160 (250)	24 / 110 (150)	24 / 160 (250)	24 / 160 (250)	6.4
	6.5	Battery weight	kg	36,4	123 (152)	150 (220)	123 (152)	150 (220)	150 (220)	6.5
Others	8.1	Drive control		Eletronic	Eletronic	Eletronic	Eletronic	Eletronic	Eletronic	8.1
	8.4	Average noise level, driver's ear	dB (A)	< 70	< 70	< 70	< 70	< 70	< 70	8.4

The values presented are to be taken as indicative and not binding; they refer to the standard equipmen

TL
 (1) Value referred to fork length L = 1150 mm
 (2) With battery 24V / 150 Ah
 (3) With battery 24V / 250 Ah

(4) Refer to enclosed table for different fork length
 (5) If for geometric limit
 (6) Value referred to fork length l = 1600 mm with battery 250 Ah

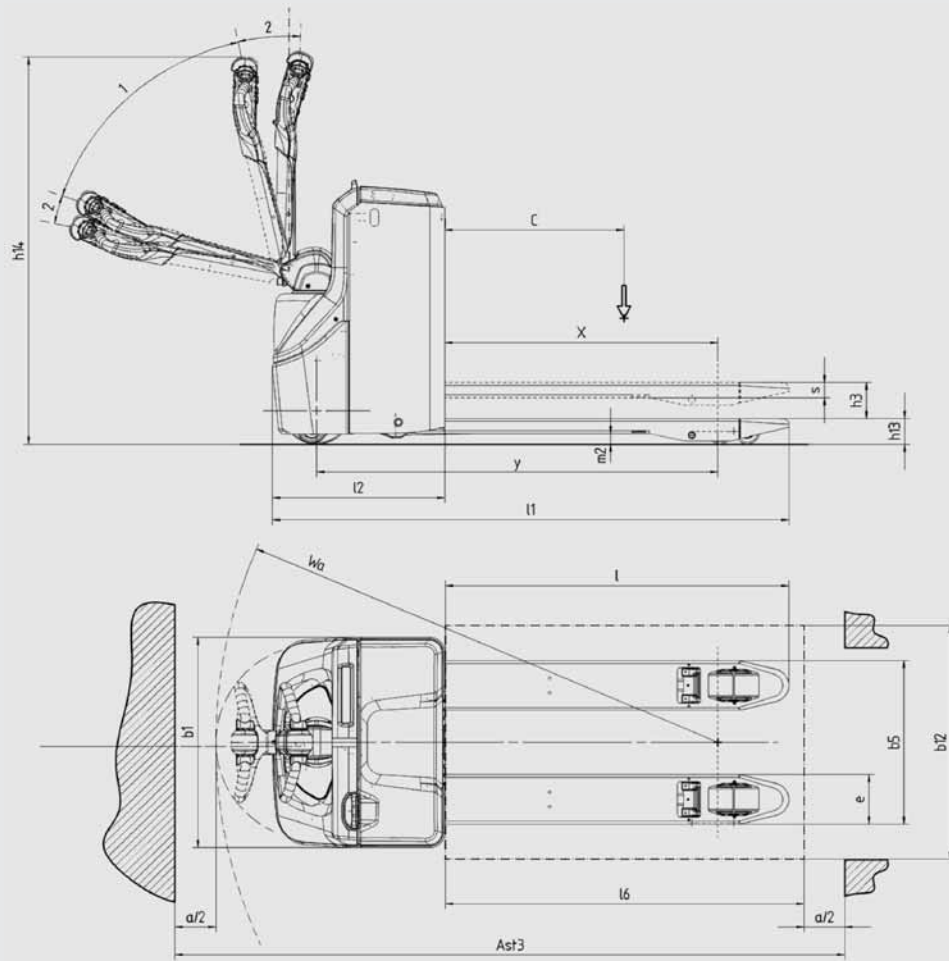

1 = Travel
2 = Braking

TL									
Forks		British Standard battery compartment				DIN Standard battery compartment			
l mm	c mm	x mm	y mm	l ₁ mm	W _a mm	y mm	l ₁ mm	W _a mm	
980	500	744	1105	1490	1441	1172	1557	1508	
1150	600	914	1275	1660	1611	1342	1727	1678	
1450	750	1214	1575	1960	1911	1642	2027	1978	
1600	800	1364	1725	2110	2061	1792	2177	2128	

HOW TO CHOOSE A PALLET TRUCK

Average load [kg]	Light Duty (2 h/shift)	Medium Duty (5 h/shift)	Heavy Duty (8 h/shift)
2200-3000	TN 30	TN 30	TN 30
2000-2200	TN 22	TN 22	TN 30
1600-2000	TL 20	TL 20	TL 20/ TN 22
1400-1600	TL 16	TL 16/ TL 18	TL 18/ TL 20
1000-1400	TL 14	TL 14/ TL 16	TL 16

TL pedestrian powered pallet truck



The range: it includes various models with capacity from 1.400 kg (with GEL battery) for light duty applications, up to 1.600 kg capacity for the major needs and up to 1.800 kg and 2.000 kg capacity for more intensive tasks.

Chassis:

- The battery compartment, completely protected by steel plates, allows to hold DIN as well as BS standard batteries. Batteries are normally removed from the top.
- The forks rod works in a "push" mode, improving the crossway pallet entry.
- Painting process follows the most advanced technology procedures.
- High resilient polyethylene covers resist even to strong hits without permanent deformations or breakings.

Tiller:

- Tiller body with new design, extremely ergonomic handgrip and arrangement of buttons that allows to use both hands equally.
- Tiller arm shape and position allow to work easily even in tight spaces.
- The lightweight of the tiller and the ease of commands handling allow the truck continuous use at the minimum operator fatigue. On release, the tiller returns to the vertical position, always with the maximum safety conditions for the operator. It is available as option (standard on TL18 and TL20) the feature "Always Active Tiller", that is the possibility to drive the truck, even if with reduced speed, with the tiller in vertical position, too.

Drive:

- AC traction motor rated 1 kW ensuring same performances both with or without load. The AC technology allows further energetic saving and maintenance cost reduction.

Electronic system:

- Static control high frequency electronics on all the range.
- The electronics incorporate a regenerative braking system to pursue energy recovery on release of the accelerator.
- As standard on TL18 and TL20 the hour-meter integrates the battery charge status indicator.
- Avant-garde electronics ensure low power consumption and silent operation. The control system protects the motors and the battery from precocious wear, avoiding high currents achievement.

Braking system:

- The trucks are provided with two different braking systems: a reverse current braking and an automatic electromagnetic parking brake started by a microswitch on the tiller, which puts itself in action at both the two extreme tiller positions.

Maintenance:

- Readily accessible lifting points on the trucks facilitate battery installation and removal operations.
- According to customer requirements and in the complete respect of the normative, OM staff can reprogram all the acceleration, braking and speed parameters, via the electronic control system.
- The first service is due at 1.000 operational hours, except just for those components which refer to specific normative.

The technical characteristics provided are representative only.

OM Carrelli Elevatori reserves the right to modify the technical characteristics with no advance notice.

OM Carrelli Elevatori S.p.A.
Viale A. De Gasperi, 7
I-20020 Lainate (MI)
Tel.: +39(02)937 65-1
Fax: +39(02)937 65-450
www.om-mh.com